

Friends of the Willow Glen Trestle:
info@WGTrestle.org
Nov. 6, 2013

The Willow Glen Trestle

Location of the Willow Glen Trestle



Hidden in Plain Sight



VIEW OF WILLOW GLEN TRESTLE
FROM COE AVENUE

Gateway to Willow Glen



VIEW OF WILLOW GLEN TRESTLE
FROM SOUTHBOUND LOS GATOS CREEK TRAIL

Not a Technical Challenge

cheaper to restore
than to replace

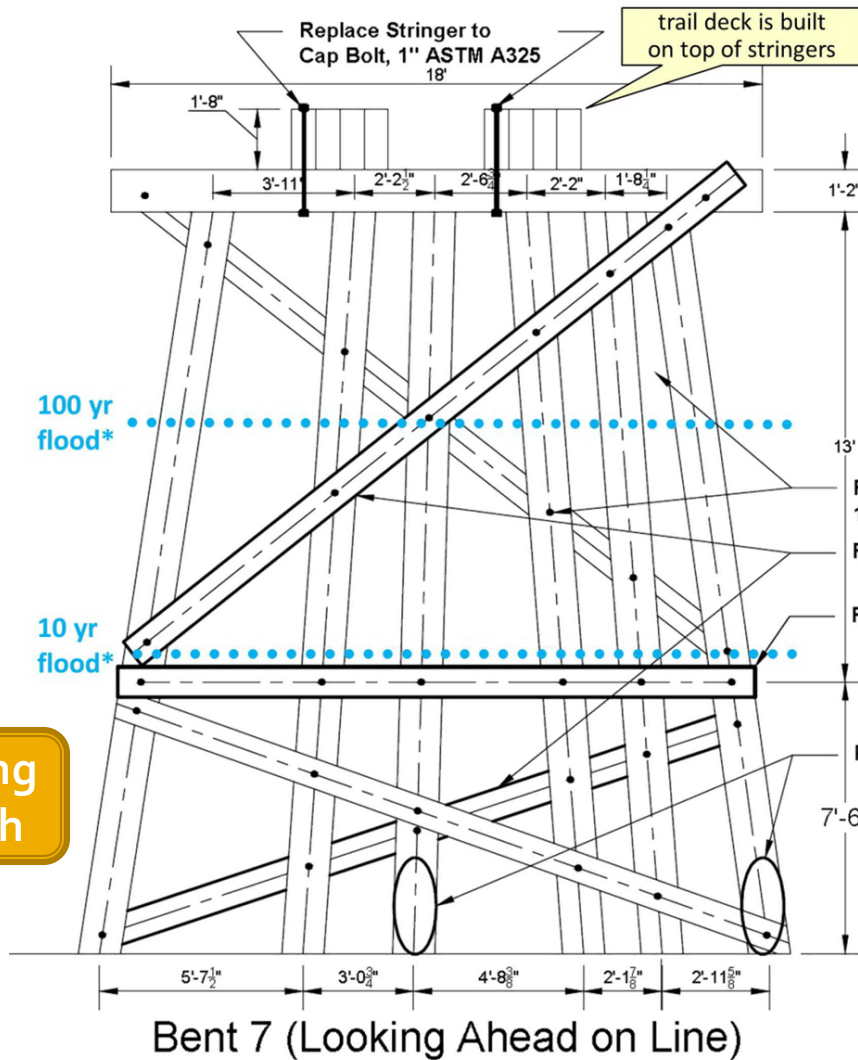

Bent 7 Pile Diameters				
Pile	Circ. Top (in)	Circ. Bott. (in)	Dia. Top (in)	Dia. Bott. (in)
1	43	39.5	14	13
2	41.5	37.5	13	12
3	47	41	15	13
4	40	40	13	13
5	42.5	38	14	12
6	43	40	14	13

Note: Pile 1 is on the left (west edge) when looking ahead on line

Note: Spacing of piles at top and bottom are approximations obtained by using the spacing at the sash and the slope of the pile. These values may vary slightly.

Replace All Bracing Bolts,
1" ASTM A325

Replace Braces

Replace Both Sashes

Piling Repair

* note: flood-levels are from SJ's Init.Study/Neg.Dec. for Reach 4 of the LG Crk Trail, (Coe to Auzeais), June 2004, p. 23.

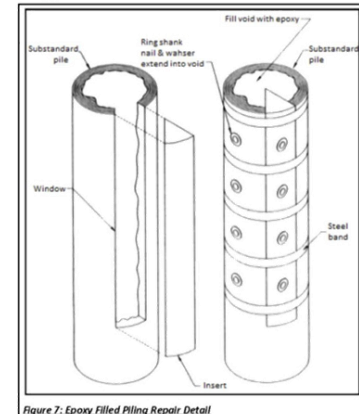
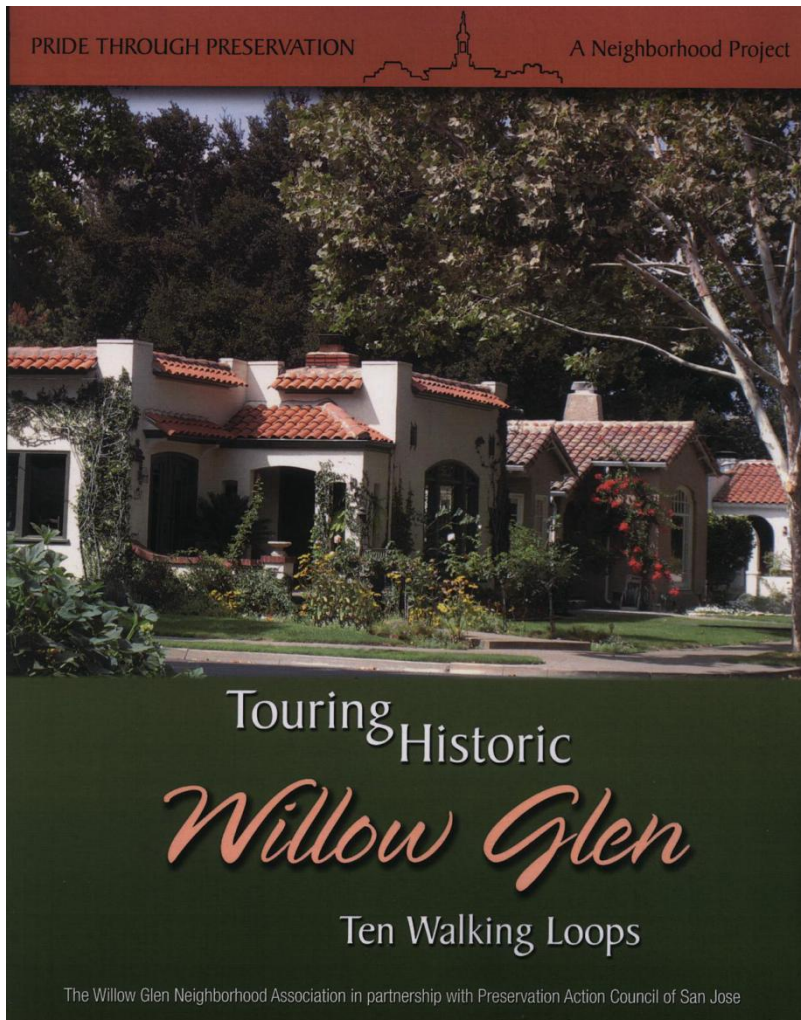

Figure 7: Epoxy Filled Piling Repair Detail

210' long
25' high

History of Willow Glen



- Trains & Canneries were integral to the founding of Willow Glen
 - suit regarding train crossings went all the way to the US Supreme Court
- The WG Trestle was built in 1921
 - just after end of the World War
 - design was not “typical” due to wartime shortages & desire to open quickly
 - minimal possible to carry the weight: trains always went “dead slow.”
- An unusual and rare trestle design to meet the needs of the times
 - still basically in original condition

Part of the History of Willow Glen



- Alignment critical in the Southern Pacific RR vs. Western Pacific RR wars
- This alignment triggered the fight against SPRR.
- SPRR picked alignment around SJ; didn't want to build grade separations.
- This freight alignment was the key linchpin that pushed support for grade separation in the region: part of the grade separation movement that was just barely extent in 1917 but widespread by 1925

Next step

- City releases the “Initial Study and Mitigated Negative Declaration” (IS/MND) for public review and comment, in Nov.(?)
 - Details the plans on how trestle is to be demolished & replaced
 - Required to discuss enviro’nmntl, aesthetic, and historic aspects
 - Organizations and individuals are encouraged to read IS/MND & give comment for the record
 - City then has to make mitigations and/or accommodations as appropriate



Worth Saving this part of SJ History



www.WGTrestle.org